

Line E/EP

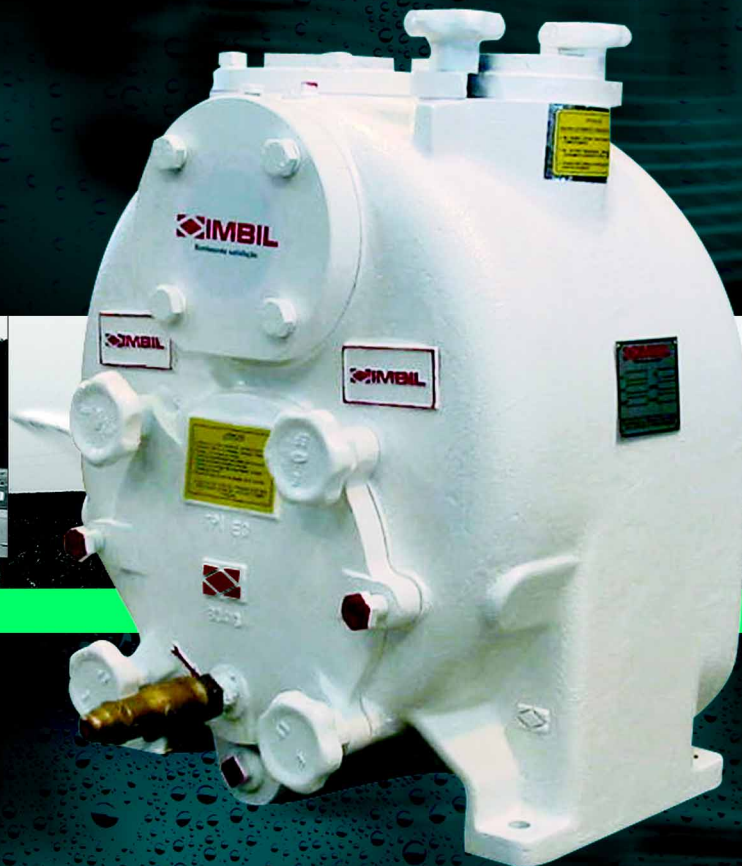



INTRODUCTION

This catalog describes all pump models of the E and EP series and their accessories and optional parts manufactured by IMBIL and includes technical information on construction techniques, applications, operating principles, design, special features and attributes of the line, in addition to dimensional drawings and characteristic curves of each model.

ADDITIONAL INFORMATION

If you have any questions regarding our products and services, IMBIL and its representatives are always at your service to provide you with any further information and technical assistance.

NOTES

We reserve the right to make any modifications that we deem necessary or required to our products at any time without entailing any obligations of any nature.



PRODUCT CHARACTERISTICS

APPLICATIONS:

Offering a diversified range of applications because of its differentiated design characteristics and concepts, IMBIL re-self-priming pumps are mostly used in sewage treatment lift stations and performs its crucial role as the heart of pumping systems, such as:

- Chemical Industries
- Chemical Effluent Treatment Plants
- Pulp and Paper Paste
- Petrochemicals
- Raw Water Collection
- Public Water supply Pipelines
- Agriculture
- Industrial Cooling Systems

These re-self-priming pumps offer distinct advantages over conventional centrifugal pumps. The first advantage reflects its own denomination: there is no need for it to be primed at the start of operation even if the suction piping lacks fluids.

- Fluids containing solids with diameters up to 3"
- Paper paste
- Sewage
- Industrial Effluents
- Transport and spraying of liquids, fertilizers and animal manure
- Flushing liquids

There are some of the fluids that IMBIL re-self-priming pumps are currently pumping in many different facilities.





DESIGN

The design of the E & EP re-self-priming pumps was developed to provide the final customer with safety, operating facility, maintenance and freedom of configuration in the application according to its needs. The design intended to provide easy maintenance ensures that the manhole and the rotating assembly are removed without affecting the suction and discharge pipings.

In a very simplified design, any foreign matter that may be interfering in the performance of the equipment may be detected and removed through the manhole with no contact with the fluid.

COMPONENTS

Mechanical Seal

One-spring mechanical seal, with oil-bath lubricated faces. It can be made in AISI 316 or AISI 420 steel models with Viton seal and bellows, rotating face and massive stationary seal in silicon carbide.

Obs.:The construction materials depend on the fluid to be pumped.





Rotor

The open impeller takes in solid matter up to the following dimensions:

Model	E1 1/2	E2	E3	E4, E6, E8, E10 and E12	EP3, EP4 and EP6
Maximum diameter of solids	1"	1 1/2"	2.1/2"	3"	1"



Back vanes lessen the pressures in the seal housing and prevent the deposition of impurities and/or foreign matter in the back area of the rotor.

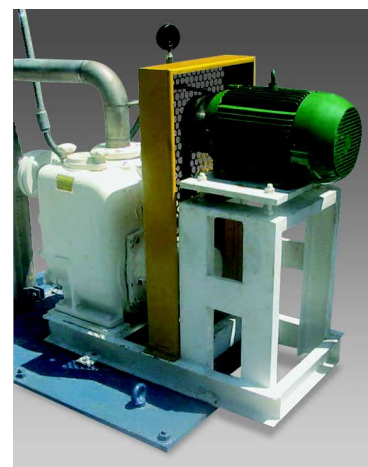

Driver

The belt and pulley transmission facilitates changing the application range and working points.



Flap

IMBIL re-self-priming pumps are equipped with FLAP valves whose function is to keep the suction piping full to make self-priming easier.



PRODUCT CHARACTERISTICS:

- Changes in hydraulic conditions with the use of simple and low-cost V-shaped belts;
- Low cost maintenance, coupled to standard or stand-alone engines. They are also available with high yield engines;
- Quick and easy adjustment of pump impeller clearances against wear plates thus ensuring 100% of the original efficiency;
- Cavitation noise may be easily identified and properly corrected;
- The impeller, the seal and the wear plate may be easily replaced through the manhole.
- The pumps and the air relief valves are easily accessible in a dry and safe environment.
- Any obstruction may be removed through the manhole without affecting the pipings.
- Maintenance and repair may be safely performed without the need of special tools or lifting equipment.
- Breakdown problems or preventive maintenance requirements may be easily addressed by using suction and discharge pressure gauges.
- The external part of the pumps, valves and assembly equipment are not exposed to sewage or gases. Performing maintenance on the equipment is simple and safe.
- All repairs are easily carried out by previously trained maintenance staff.
- The assembly is usually located above ground level and is not subject to flooding.
- No guide trail system is required.
- Preventive maintenance is easily performed.
- Any leaks in the piping are visible and may be easily repaired.
- The pump assemblies are fully factory-mounted and tested.
- No lifting equipment is required for regular maintenance procedures.



OPERATING PRINCIPLE

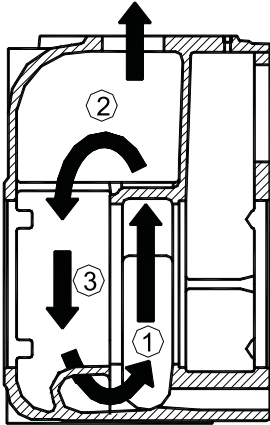

Re-priming:

If the suction piping is not full of fluid when the pump is switched on, the priming process is started providing it with the property of being re-self-priming. The fluid + air inside of volute case (1) re-circulating between the chambers (2) and (3) returning through the recirculation channel to the inside of volute case. This process is repeated many times until all the air is eliminated.

Pumping:

When the priming process is complete, the pump starts its regular operation as a conventional centrifugal pump and the stop valve is not required in the recirculation channel because it is located in a section of the volute case designed for this specific purpose.

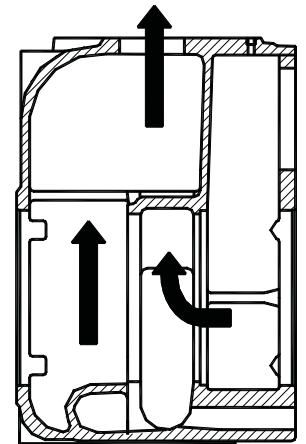

AXIAL ADJUSTMENT TO MAINTAIN EFFICIENCY

In order to maintain original efficiency of equipment, the re-self-priming pumps have axial adjustment to deal with the clearance found between the wear plate and the impeller.

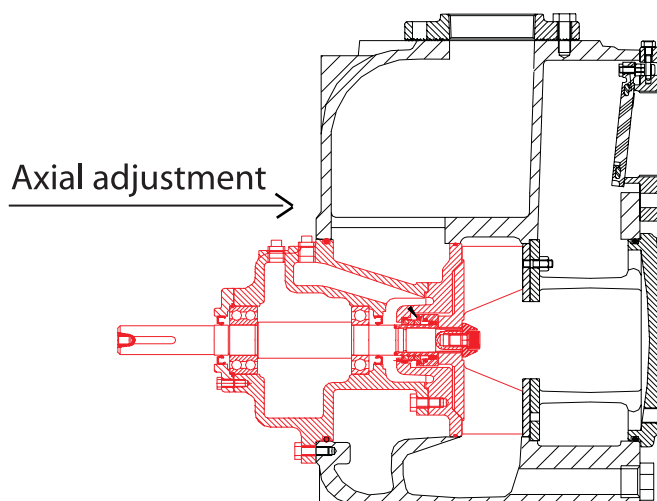



APPLICATION CHART

E LINE

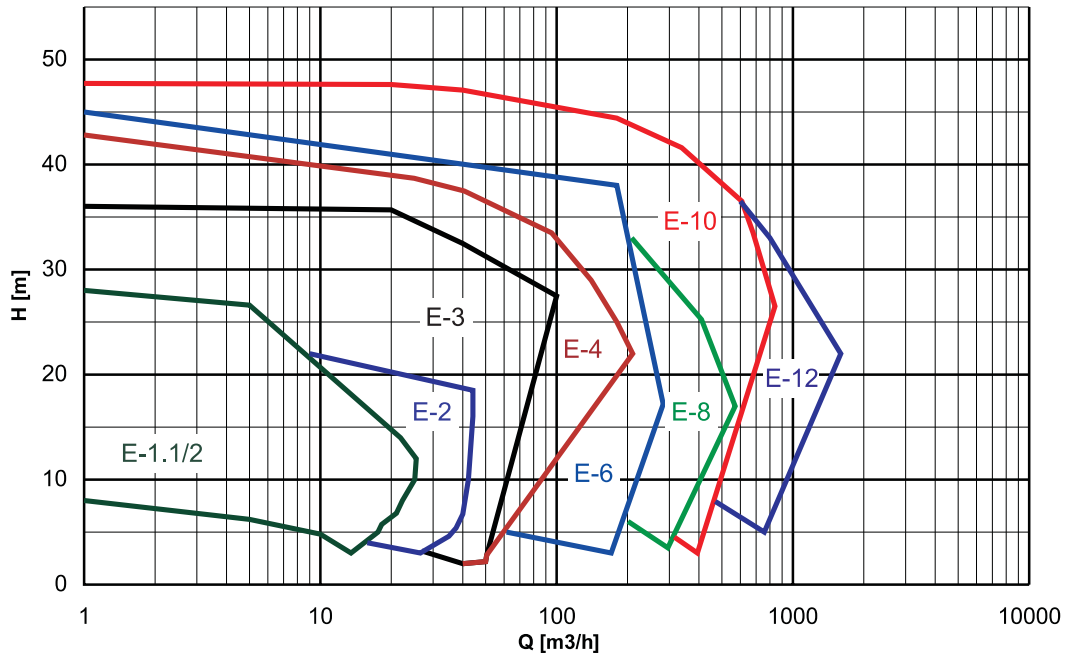

EP LINE

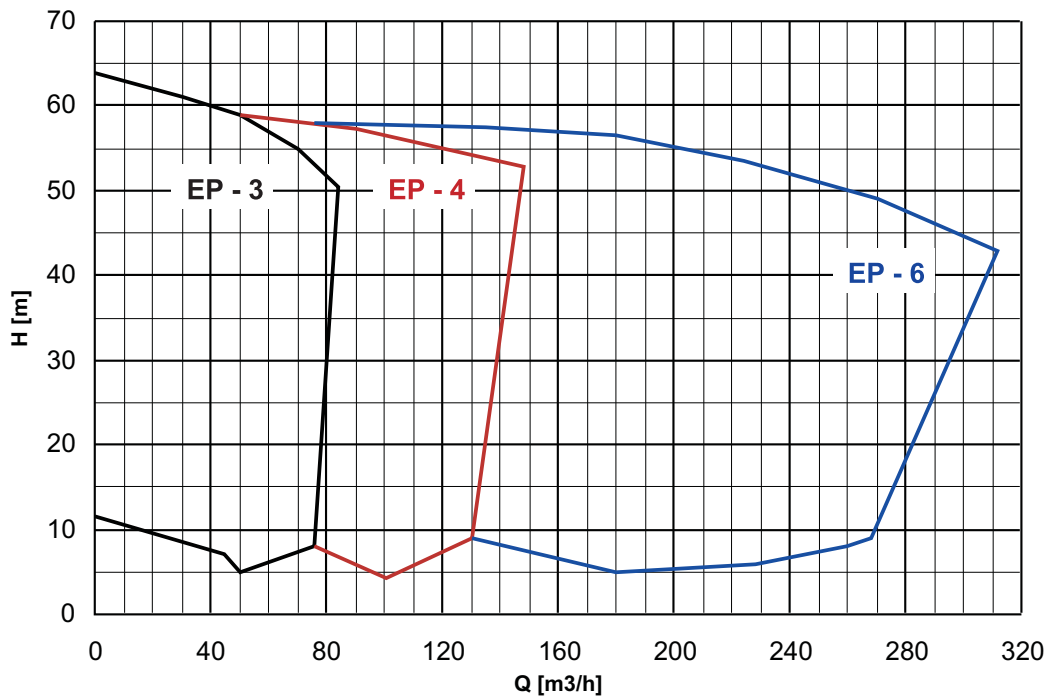



CONSTRUCTION MATERIALS

COMBINED VERSIONS OF MOSTLY USED MATERIALS

	V01	V02	V03	V04	V05	V06	V07	V08	V09	V10
Suggested application	Water, sewage, mineral oil, aqueous solutions, compatible.	Mineral oil, vegetal oil, aqueous solutions, sewage.	Mineral oil, vegetal oil, aqueous solutions.	Mineral oil, sewage, milk, vegetal oil, fruit juices, compatible acids.	Mineral oil, fruit juices, compatible acids, aqueous solutions.	Sewage with sand, abrasive fluids.	Mineral oil, milk, fruit juices, compatible acids, aqueous solutions.	Water, sewage, mineral oil, aqueous solutions, compatible.	Mineral oil, milk, fruit juices, compatible acids, aqueous solutions.	Mineral oils, fruit juices, compatible acids, aqueous solutions.
Volute Case	ASTM A 536 65-45-12	ASTM A 536 65-45-12	ASTM A 536 65-45-12	ASTM A 351 Gr.CF8M	ASTM A 351 Gr.CD4MCu	ASTM 743 Gr.CA40	ASTM A 351 Gr.CA6NM	ASTM A 536 65-45-12	ASTM A 351 Gr.CF8M	ASTM A 351 Gr.CD4MCu
Impeller	ASTM A 536 65-45-12	ASTM A 351 Gr.CF8M	ASTM 743-98 Gr.CA6NM	ASTM A 351 Gr.CF8M	ASTM A 351 Gr.CD4MCu	ASTM 743 Gr.CA40	ASTM A 351 Gr.CA6NM	ASTM A 536 65-45-12	ASTM A 351 Gr.CF8M	ASTM A 351 Gr.CD4MCu
Wear plate	SAE 1020	ASTM A 351 Gr.CF8M	ASTM A 351 Gr.CF8M	ASTM A 351 Gr.CF8M	ASTM A 351 Gr.CD4MCu	ASTM 743 Gr.CA40	ASTM A 351 Gr.CA6NM	SAE 1020	ASTM A 351 Gr.CF8M	ASTM A 351 Gr.CD4MCu
Manhole	ASTM A 536 65-45-12	ASTM A 536 65-45-12	ASTM A 536 65-45-12	ASTM A 351 Gr.CF8M	ASTM A 351 Gr.CD4MCu	ASTM 743 Gr.CA40	ASTM A 351 Gr.CA6NM	ASTM A 536 65-45-12	ASTM A 351 Gr.CF8M	ASTM A 351 Gr.CD4MCu
Seal Case	ASTM A 48 CL30	ASTM A 48 CL30	ASTM A 48 CL30	ASTM A 351 Gr.CF8M	ASTM A 351 Gr.CD4MCu	ASTM 743 Gr.CA40	ASTM A 351 Gr.CA6NM	ASTM A 48 CL30	ASTM A 351 Gr.CF8M	ASTM A 351 Gr.CD4MCu
Flap	NEOPRENE / VITON*									
Flanges	ASTM A 48 CL30	ASTM A 48 CL30	ASTM A 48 CL30	ASTM A 351 Gr.CF8M	ASTM A 351 Gr.CD4MCu	ASTM 743 Gr.CA40	ASTM A 351 Gr.CA6NM	ASTM A 48 CL30	ASTM A 351 Gr.CF8M	ASTM A 351 Gr.CD4MCu
O'rings	NITRILICA / NEOPRENE / VITON*									
Shaft	AISI 420	AISI 420	AISI 420	AISI 420	AISI 420	AISI 420	AISI 420	AISI 630	AISI 630	AISI 630

Notes: (*) Material specification depends on application. Supply of other materials on demand.

MINIMUM RECOMMENDED SUBMERGENCE FLOW SPEED

The minimum recommended submergence, which is the level difference between the suction tank level and the suction piping inlet, must be verified so that vortex formation is avoided in the pump suction which would adversely affect the pumping.

The length of the immersed suction line is critical for proper operation of the pump, that is, it affects its yield. The graph below shows the minimum recommended submergence X flow speed.



SUCTION FLOW SPEED ACCORDING TO RECOMMENDED MINIMUM SUBMERGENCE

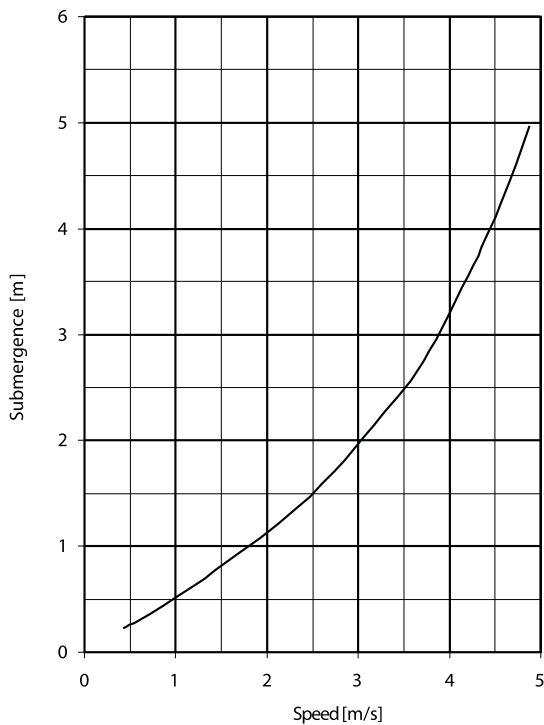

Note 1: The use of suction piping with the same diameter of the pump inlet is recommended so that solid matter can be fully dragged;

Note 2: If suction flow speed is higher than 3.6 m/s, contact us for optional accessories and arrangements applicable in such conditions.

Recommendation related to the use of suction piping

Considering that the inlets to the suction tank cannot be placed too close to the pump suction piping, we recommend that the suction tank inlets should be placed at a distance at least twice the diameter of the suction piping.

When we have two suction pipings in the same suction tank, the pipings must be distant at least three times the diameter of the piping.

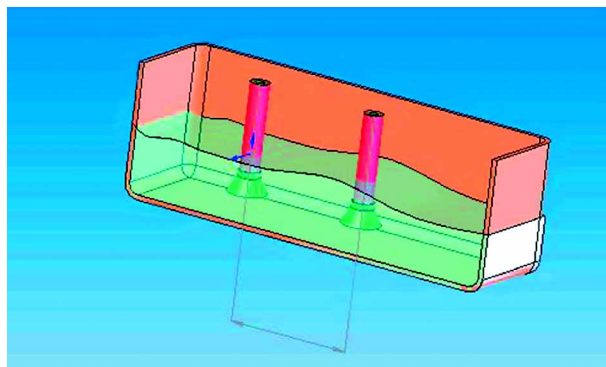
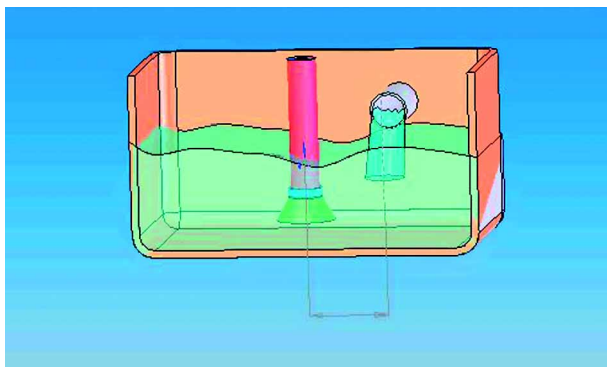



INSTALLATION DRAWING

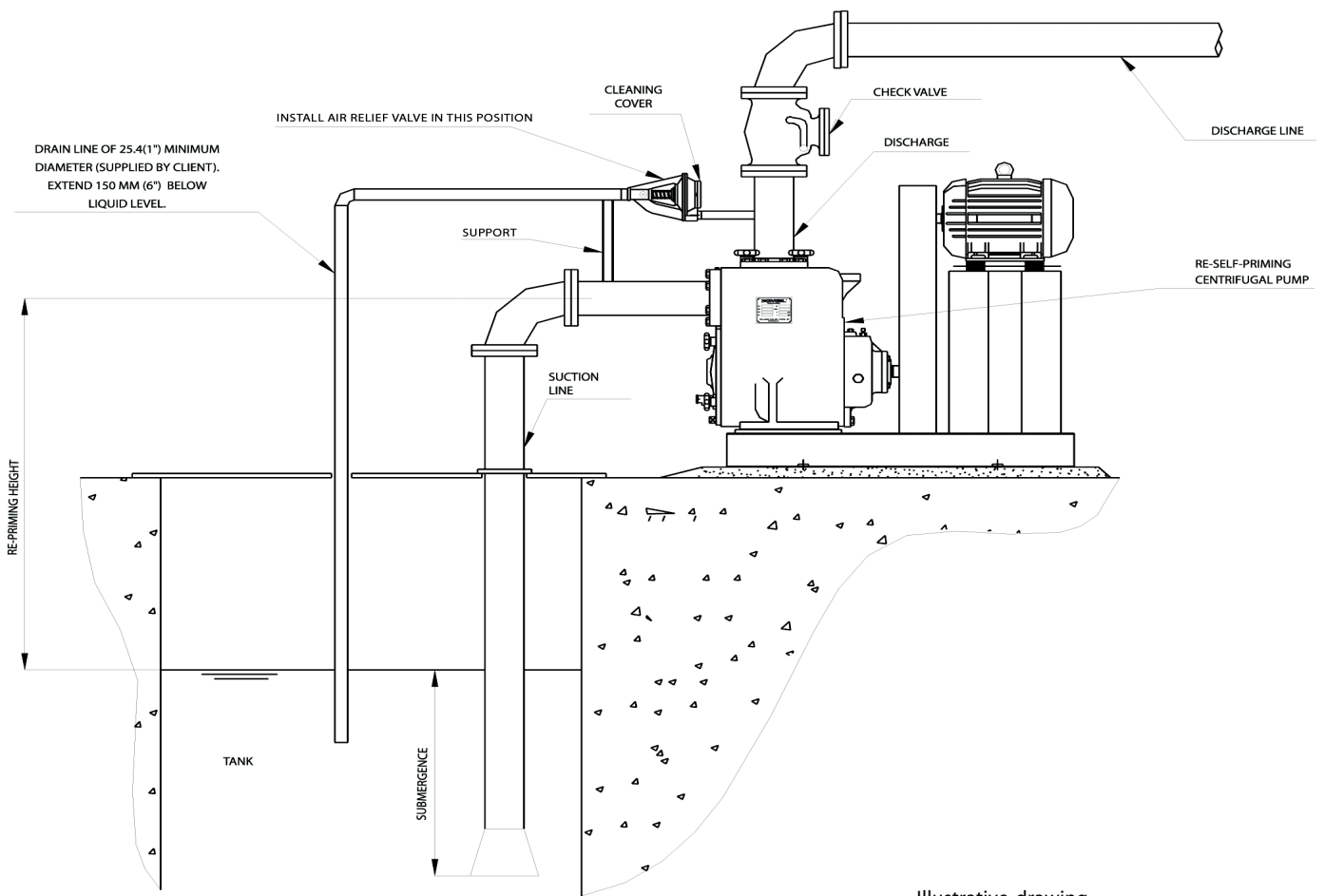

Illustrative drawing



FLANGES

As a standard, IMBIL re-self-priming pumps are usually supplied with screw thread flanges of 1.1/2" up to 8", depending on the pump model. Nevertheless they may be supplied with double flange, of the reel type, according to the standards and dimensions described below:

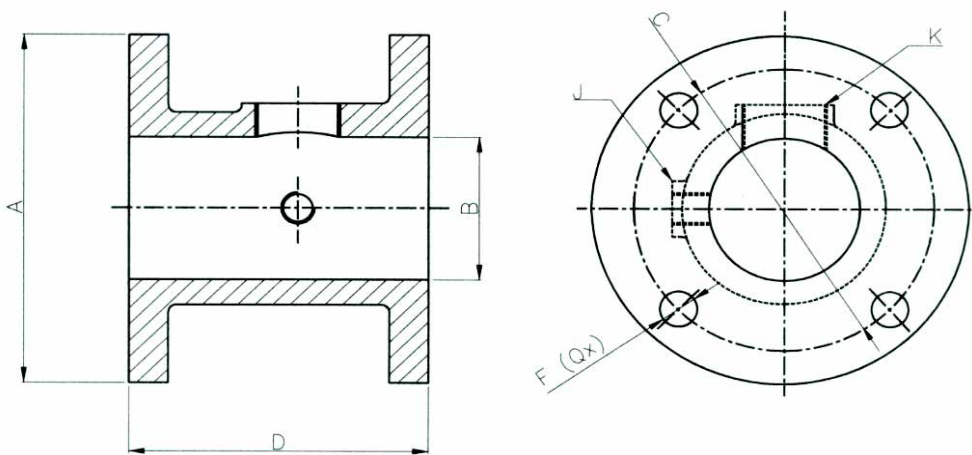

Model	Standard	Pressure							Suction						
		A	B	C	F x Q	D	K	J	A	B	C	F x Q	D	K	J
E3/EP3	ANSI B 16.1 FF	189	76,8	152	19 X 4	152	3/4" NPT	1/4" NPT (1x)	192,5	76,8	152	19 X 4	139,5	3/4" NPT	1/4" NPT (1x)
	DIN 2533 PN 16	190	76,8	150	18 X 4	152	3/4" NPT	1/4" NPT (1x)	190	76,8	150	18 X 4	152	3/4" NPT	1/4" NPT (1x)
E4/EP4	ANSI B 16.1 FF	230	103	190	19 X 8	122	3/4" NPT	1/4" NPT (1x)	230	101,5	190	19 X 8	116	3/4" NPT	1/4" NPT (1x)
	DIN 2533 PN 16	210	103	170	18 X 4	122	3/4" NPT	1/4" NPT (1x)	210	101,5	170	18 X 4	116	3/4" NPT	1/4" NPT (1x)
E6/EP6	ANSI B 16.1 FF	280	152	241,3	22 X 8	178	3/4" NPT	1/4" NPT (1x)	282	152	241,3	22 X 8	164	3/4" NPT	1/4" NPT (1x)
	DIN 2533 PN 16	264	152	225	18 X 8	178	3/4" NPT	1/4" NPT (1x)	264	152	225	18 X 8	164	3/4" NPT	1/4" NPT (1x)
E8	ANSI B 16.1 FF	344,5	204,5	298,5	22 X 8	152,5	3/4" NPT	1/4" NPT (1x)	345	203	299	22 X 8	128,7	3/4" NPT	1/2" NPT*
	DIN 2533 PN 16	340	204,5	295	23 x 12	152,5	3/4" NPT	1/4" NPT (1x)	340	203	295	23 x 12	128,7	3/4" NPT	1/2" NPT(2x))

*Has an extra connection 1/4" NPT



AIR RELIEF VALVE

We recommend the use of air relief valve in lines of re-self-priming discharge pumps to remove the air trapped inside the pump and making self-priming easier.

OPERATION

During pump priming the air flows from the inside of the pump to the by-pass line. When the pump is in full priming, the fluid pumped will apply pressure on the diaphragm that will compress the spring thus closing the valve. When the pump interrupts operation, the pressure ceases and the springs opens the valve back, therefore preparing the system for a new priming.

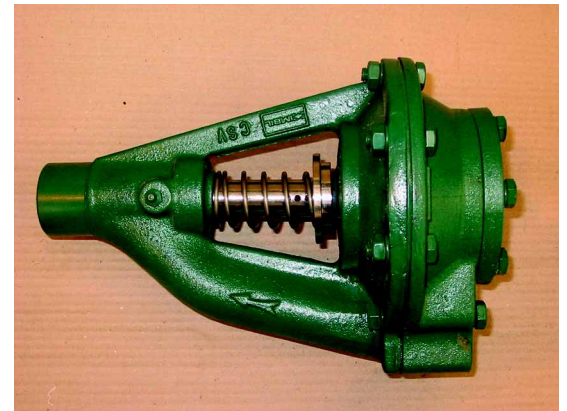

INSTALLATION

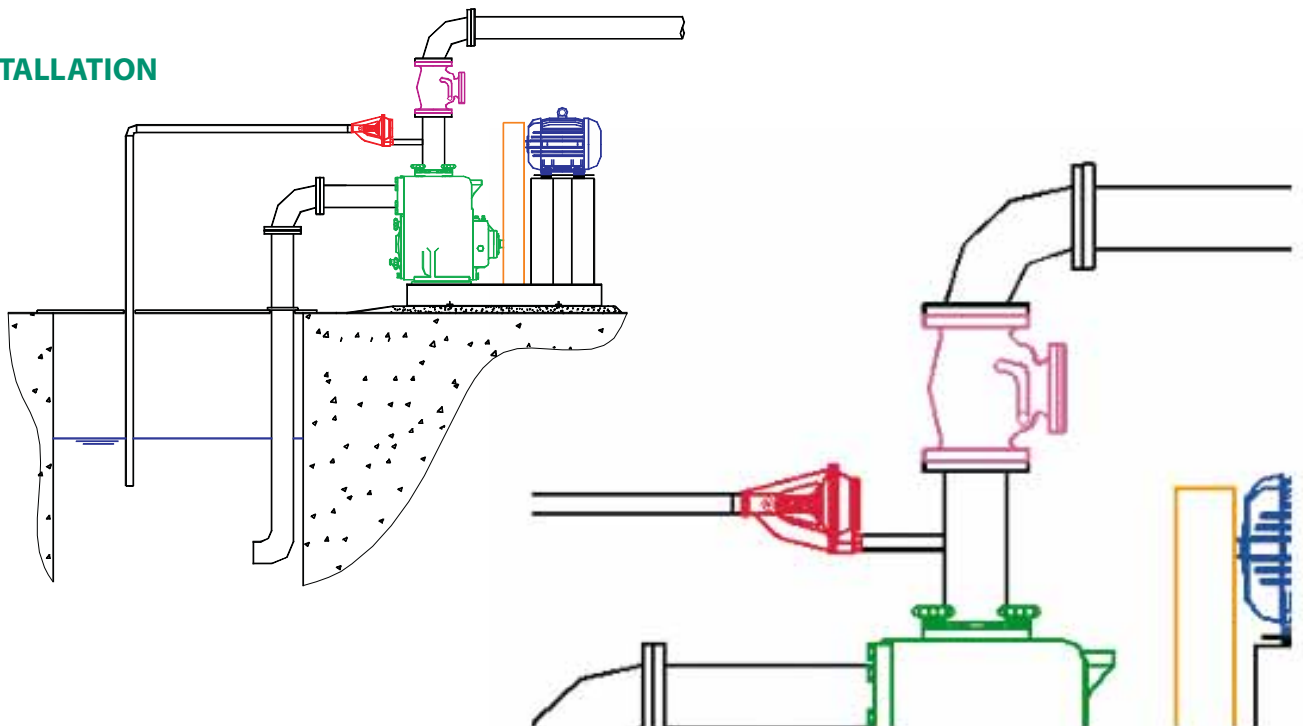



Selection & Application of Air Relief Valves

Operating range of valve

Pump discharge pressure	Unit	Spring Color
1,2 - 5,5	mca	Red
5,5 - 15	mca	Not Painted
Over 15	mca	Black

AIR RELIEF VALVE DIMENSIONS

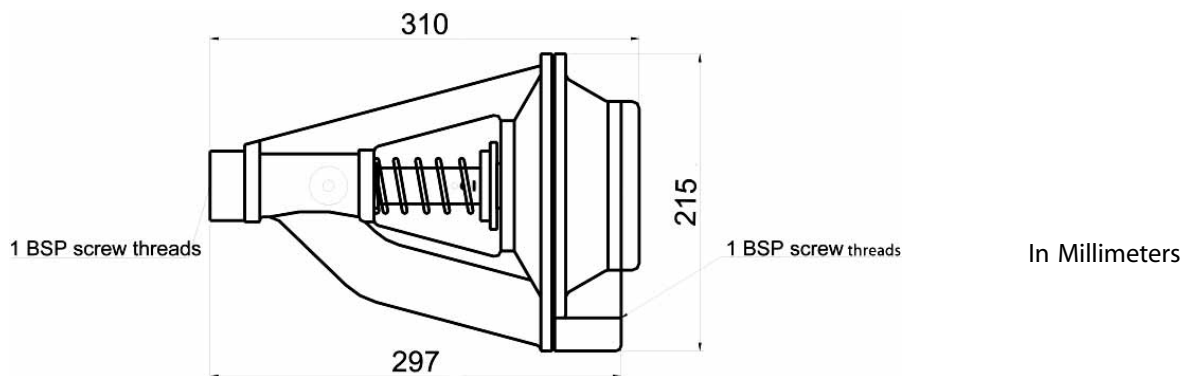

PART LIST & CROSS SECTION VIEW

Item	Description	Material Standard	Quantity
1	Outlet part	ASTM A48 CL30	1
2	Inlet part	ASTM A48 CL30	1
3	Inlet part cover	ASTM A48 CL30	1
4	Shaft	AISI 316	1
5	Spring	AISI 302	1
6	Washer spring lock	AISI 304	1
7	Diaphragm	NBR / Viton	1
8	Diaphragm fixation washer	AISI 304	2
9	Sealing O'ring shaft	NBR / Viton	1
10	Sealing O'ring cover	NBR / Viton	1
11	Retainer	NBR	1

